

# EJECTOR PINS

THROUGH HARD — NITRIDED — SHOULDER — INCH

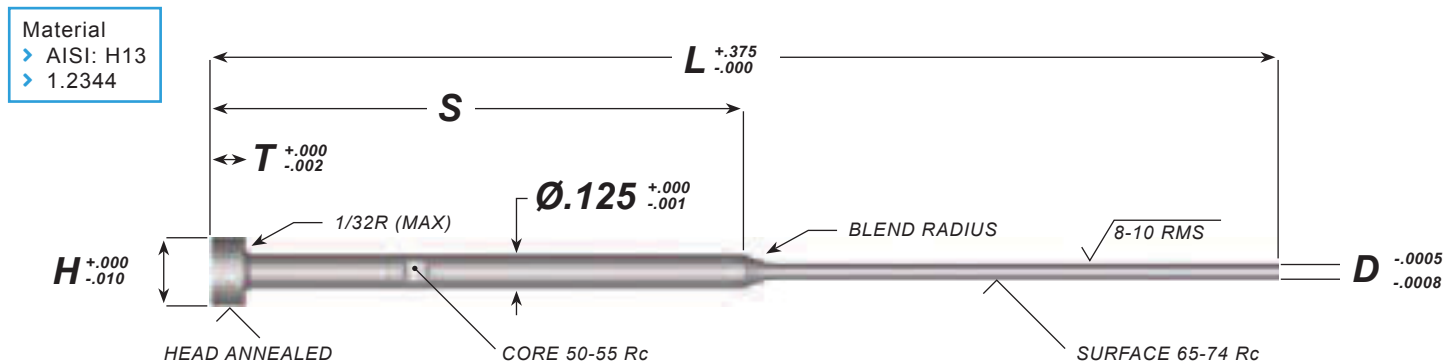

D	S	Cat. No.	L					H	T
			STD.	STD.	+0.005	STD.	+0.005		
1/32	1/2	RHX-02-1/2	L06					1/4	1/8
	2	RHX-02-2	L06						
	3	RHX-02-3		L10	L105				
	4	RHX-02-4		L10	L105				
3/64	1/2	RHX-03-1/2	L06					1/4	1/8
	2	RHX-03-2	L06	L10	L105				
	3	RHX-03-3		L10	L105				
	4	RHX-03-4		L10	L105				
1/16	1/2	RHX-05-1/2	L06	L10	L105			1/4	1/8
	2	RHX-05-2	L06	L10	L105	L14	L145		
	3	RHX-05-3		L10	L105				
	4	RHX-05-4		L10	L105				
5/64	1/2	RHX-06-1/2	L06	L10	L105			1/4	1/8
	2	RHX-06-2	L06	L10	L105	L14	L145		
	3	RHX-06-3		L10	L105				
	4	RHX-06-4		L10	L105				
3/32	1/2	RHX-07-1/2	L06	L10	L105			1/4	1/8
	2	RHX-07-2	L06	L10	L105	L14	L145		
	3	RHX-07-3		L10	L105				
	4	RHX-07-4		L10	L105				
7/64	1/2	RHX-08-1/2	L06	L10	L105			1/4	1/8
	2	RHX-08-2	L06	L10	L105	L14	L145		
	3	RHX-08-3		L10	L105				
	4	RHX-08-4		L10	L105				

► To order, add overall length "L" to Catalog Number. Example: RHX-02-1/2L06